



VRLA Battery User Manual

Introduction

As a world leading manufacturer of Valve Regulated Lead-Acid (VRLA) batteries, CSB's products are utilized in over 52 countries in UPS, telecommunications, emergency lighting, security and more. CSB is committed to developing next generation VRLA products and growing its worldwide distribution network. The following document describes best practices to observe and implement when handling and operating CSB Energy Technology, Co, Ltd. VRLA-AGM batteries in the following product families as listed below. All information is subject to change without prior notification. For the latest information, please contact a CSB representative.

Disclaimer

Images contained in this manual are for illustrative purposes only. These images may not match your installation. Operator is cautioned to review the drawings and illustrations contained in this manual before proceeding. If there are questions regarding the safe operation of the batteries, please contact your local CSB Energy Technologies, Co, LTD office or your nearest CSB representative. CSB shall not be held liable for any damage or injury involving its batteries or other hardware if used or operated in any manner or subject to any condition not consistent with its intended purpose or is installed or operated in an unapproved manner or improperly maintained.

Product Families	Battery Model Number(s)
RUM	RUM6290
UPS	UPS122406, UPS123606, UPS123607, UPS12460, UPS12580
HR	HR1218W, HR1221W, HR1224W, HR1227W, HR1228W, HR1232W, HR1234W, HR1251W, HR1290W, HR12120W
HRL	HRL634W, HRL1210W, HRL1225W, HRL1234W, HRL1250W, HRL1280W, HRL12110W, HRL12150W, HRL12150WG, HRL12200W, HRL12280W, HRL12330W, HRL12330WG, HRL12390W, HRL12540W, HRL12540WG
XHRL	XHRL12170W, XHRL12200W, XHRL12250W, XHRL12360W, XHRL12360WG, XHRL12410W, XHRL12410WG, XHRL12475W, XHRL12500W, XHRL12620W, XHRL12620WG, XHRL12650W, XHRL12650WG
XHRL-FT	XHRL12600WFT, XHRL12800WFT, XHRL12900WFT
XPL	XPL2000, XPL2200, XPL2700, XPL3500, XPL4200, XPL4700, XPL5700, XPL6700, XPL6700G
XPL-FT	XPL7000FT, XPL8000FT, XPL9000FT
GP	GP645, GP672, GP6120, GP1212, GP1223, GP1234, GP1245, GP1272, GP12120, GP12170, GP12260, GP12340, GP12400, GP12650, GP121000
GPL	GPL1272, GPL12120, GPL12260, GPL12400, GPL12520, GPL12650, GPL12750, GPL12800, GPL12800G, GPL12850, GPL12880, GPL121000, GPL121000S, GPL121100
EVH	EVH12140, EVH12150, EVH12240, EVH12390
EVX	EVX1272, EVX12120, EVX12170, EVX12200, EVX12260, EVX12300, EVX12340, EVX12400, EVX12520, EVX12650, EVX12750
XTV	XTV1272, XTV1272-WT, XTV1285, XTV12120, XTV12120-WT, XTV12200, XTV12200-WT, XTV12550, XTV12800, XTV12000, XTV121100
TPL	TPL12600TFR, TPL121000FR, TPL121000TFR, TPL121250AFR, TPL121600FR, TPL121800FR, TPL122000FR
MSV	MSV-200, MSV-300, MSV-400, MSV-500, MSV-650, MSV-800, MSV-1000
MSJ	MSJ-150, MSJ-200, MSJ-260, MSJ-300, MSJ-400, MSJ-500, MSJ-650, MSJ-800, MSJ-1000
MU	MU900S, MU1000S, MU1500S, MU-1000
RE	RE1200, RE1700



VRLA Battery User Manual

1. Battery Construction

Unlike the traditional flooded type of lead acid batteries, valve-regulated lead acid (VRLA) batteries use an electrolysis of water from the electrolyte caused by overcharge. This generates oxygen (O₂) gas on the positive plates and can be absorbed by the hydrogen (H₂) gas on the negative plates. These gases are recombined and not expelled so water can be kept without loss.

General Construction

The main components of a VRLA battery are (+) positive and (-) negative plates, separator, container, middle cover, vent caps, safety valve, electrolyte, and terminals.



Plates

Both positive and negative plates consist of the grid and the paste attached to it. The grid of the CSB VRLA is made of lead calcium (Pb-Ca) alloy with superior mechanical properties, and the active materials of the paste consist of lead oxide (PbO), sulphuric acid and other materials that can enhance battery performance.

Safety Valve

This is an explosion-proof relief valve that can help reduce pressure and is able to resist acid overflow. The open pressure of the safety valve is 0.1~0.3kgf/cm². Whenever the internal pressure increases up to the preset limited value, this valve begins to act and will release excessive gas, and the valve automatically seals up to prevent the entrance of oxygen from the air into the cell.

Container and Cover

With the minimum level of oxygen index over UL 94-HB, the material used is flame retardant, shock proof, acid-resistant, has high mechanical strength, and resists oil organic solvent or oil-made product. Permanent airtight sealing between the cover and the container will prevent the electrolyte, lead, and air from escaping.

Electrolyte

The electrolyte contains sulfuric acid specified under the standards of JIS K 1321. The electrolyte is absorbed by a micro-porous separator without any fluid liquid present internally. Therefore, it is immobilized, leak-proof, and can prevent stratification or dry out.

Terminals

Both the positive or negative poles are made of lead-electroplated pure copper which can resist acid and corrosion. The plate group is connected to the post by soldering. Both the post and the connectors are acid resistant and anti-corrosive for the battery to provide longer service life.

Separator

The Absorbent Glass Mat (AGM) separator functions as an electrolyte retainer and offers a high oxygen recombination efficiency, low internal resistance, and is free from producing exotic organic materials. Its surface area is sufficient to cover the plate.





VRLA Battery User Manual

2. Battery Safety

****ATTENTION** CAREFULLY READ THIS DOCUMENT SECTION.** VRLA batteries are potentially dangerous and proper precautions must be observed in handling and installation. CSB recommends only knowledgeable and trained personnel can be qualified to work on batteries with proper tools and protective equipment. Keep unauthorized personnel away from the batteries during the maintenance activities. Any deviation from not following these safety guidelines can result in serious injury or death.



Always Wear Eye Protection



Prevent Electrical Shock



No Open Flames Around Batteries



Hazardous Chemicals Present



Batteries Can Explode



Always Recycle, Do Not Throw into Trash



Electrical Hazards

Battery system presents a risk of electrical shock and high current short circuit. The following precautions must be observed when handling CSB VRLA batteries:

- Store all batteries beyond the reach of children.
 - Remove all personal metal objects from your person (watches, rings, etc.).
 - Use insulated tools and gloves.
 - Never clean battery terminals with wire brush
 - Wear full eye protection and rubber gloves.
 - Observe circuit polarities.
 - Do not make or break live circuits.
 - Do not lay metal tools on top of batteries.
 - All connection cables should be well insulated and not able to short electrically. If the cables do cause an electrical short, that may cause smoke or the battery to cause a large destructive fire.
- Prior to handling batteries on a metal rack/cabinet, assure batteries are not inadvertently grounded by observing the ground fault detecting indicator.
 - Do not use the VRLA batteries at a site that can get moist or immersed in water. Doing so can cause the battery's terminals to corrode, and/or cause electrical shock or fire.
 - Do not use any dry fabric or other materials to clean the battery that could cause static electricity. Always use a damp cloth that has had the moisture wrung out of it.
 - As appropriate, use an insulating blanket to cover exposed portions of the battery system when performing extended maintenance that could result in personal or equipment contact with the energized conductors.
 - Certain types of rectifier circuits used in charging the VRLA battery may not include a line-isolating transformer. In these cases, extreme caution must be exercised when maintaining and collecting data on the battery system.
 - VRLA batteries are sometimes enclosed in cabinets with very limited access. Again, extreme caution must be exercised when maintaining and collecting measurements on the battery system.
 - Always use the proper charger and the charging regulations set by CSB. Not following CSB guidelines and procedures, or using non-approved charging procedures, can cause the battery to leak acid, heat up, or cause a destructive fire.



VRLA Battery User Manual

2. Battery Safety (Cont.)



Fire, Explosion, and Heat Hazards

VRLA batteries can contain an explosive mixture of hydrogen gas which can vent under overcharging conditions.

- Do not smoke, introduce an open flame, spark, or extreme heat in the vicinity of the battery.
- Do not burn the battery or throw it into a fire. Doing so may cause the battery to explode and toxic gas to be released.
- Prior to handling the battery, touch a grounded metal object, such as the rack, to dissipate any static charge that may have developed on the operator's body.
- Do not charge, discharge, or store batteries in a sealed container. The individual battery should have 5 to 10mm of space between them to allow for proper cooling. If contained, assure the container, cabinet or room has adequate ventilation to prevent and accumulation of potentially vented gas.
- Never use the VRLA battery together with other types of batteries, such as dry cells and nickel-cadmium batteries. Doing so can cause explosions, fires, or bodily injury.
- When the battery approaches the end of its life, its performance will decrease very fast. The internal exhausted electrolyte and the corrosion of the positive plate may cause a failure. If the battery continues in operation under these conditions, there could be extreme heat, leaking of even explosion.
- If there is any corrosion, cracking, deformation, heat generation, or other abnormalities to the VRLA battery upon its first use after purchase, do not use it. Please call the location where it was purchased. Using the battery with an abnormality can cause the battery to leak fluid, generate heat or explode.



Battery Chemical Hazards

- Any gelled or liquid emissions from a VRLA battery is electrolyte which contains diluted sulfuric acid that is harmful to the skin and eyes. The electrolyte is also electrically conductive and corrosive.
- If the electrolyte contacts the skin, wash the area immediately and thoroughly with water. If electrolyte enters the eyes, wash eyes thoroughly for a 10-minute period with clear water or a special neutralizing eye wash solution and seek immediate medical attention.
- Neutralize any spilled electrolyte with the special solution contained in a "spill kit" or with a solution of 1 pound of bicarbonate of soda to 1 gallon of water.
- Do not disassemble, reassemble, or destroy the battery. Doing so could cause the acid inside the battery to leak and cause severe burns or other accidents.

Battery Recycling and Disposal

VRLA batteries are to be recycled. Batteries contain lead and dilute sulfuric acid. Dispose of the battery in accordance with local regulations. Do not dispose of the battery in a landfill, lake, or other unauthorized location.



VRLA Battery User Manual

3. Battery Transportation

All CSB batteries are identified as "Battery, Electric Storage, Wet, Non-spillable" when transported by air, sea or by land transportation. The batteries must be identified as above on the Bill of Lading and properly packaged with the terminals protected from short circuit. CSB batteries warning label identifies each battery as NONSPILLABLE.

CSB VRLA batteries are classified as "non-spillable" for the purpose of transportation by DOT, and IATA/ICAO as result of passing the Vibration and Pressure Differential Test described in DOT [49 CFR 173.159 (f)] AND IATA/ICAO [Special Provision A67].

CSB VRLA batteries can be safely transported on deck, or under deck stored on either passenger or cargo vessels as result of passing the Vibration and Pressure Differential Test as described in the IMDG regulations (Special Article 238).

When transporting the battery, avoid excessive vibration and impacts; CSB recommends transporting the battery in an upright position.

For all other questions, please refer to CSB SDS (Safety Data Sheet), for additional transport information.

4. Battery Storage

When placing CSB VRLA batteries into storage for later use, it is recommended to place battery indoors in a cool (25°C or less), clean and dry location. During storage, the capacity of the battery decreases due to self-discharging. The self-discharge rate of CSB VRLA batteries is approximate 3% per month at 25°C.

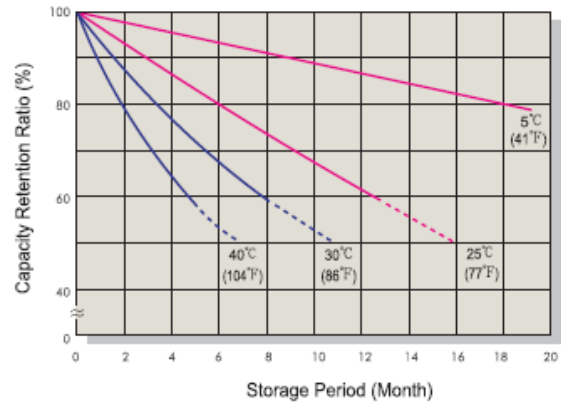

Figure 1 - Storage vs Temperature Curves

When removing batteries from storage and preparing for installation, it is recommended a boost charge be performed using the following parameters below.

Charge Method	Charge time (hours)	Ambient temperature (°C)
Constant Voltage Charging at 2.45V/Cell	8-12	5-35

When storing batteries for an extended period, please observe the recommended maintenance intervals that should be performed when stored at various temperatures.

Storage temperature (°C/°F)	Recommended supplementary charge interval	Supplementary charging methods
Lower than 25°C (77°F)	Each 6 months	16 to 24 hours with a constant voltage of 2.275 V/cell.
25 - 30°C (77-86°F)	Each 3 months	
Over 30°C (86°F)	Storage to be avoided	5 to 8 hours with a constant voltage of 2.45V/cell.



VRLA Battery User Manual

5. Battery Installation

Battery Unpacking

Upon arrival of batteries to desired location for installation, unpack carefully and exercise caution to not give the batteries any physical shock, which can cause damage to the blocks. Do not carry and lift batteries by its terminals.

After unpacked, check for any physical defects on the batteries. If any damage to the jar, acid leakage or any abnormality is detected, separate the blocks with mentioned issues and do not use.

Installation Design Criteria

Consideration that should be included in the design of the battery installation depends on the requirements or functions of the system. Please find the following recommended installation design criteria for CSB VRLA batteries.

Grounding and Bonding Inspection: After assembly completion, the grounding and bonding system must undergo inspection to ensure its resistance does not exceed 0.1 Ω .

Dielectric Voltage Withstand Test: If the nominal maximum battery system voltage of 60 VDC is exceeded, the assembly must undergo a repeat of the dielectric voltage withstand test at the higher voltage level.

Location

Space allocated for the battery and associated equipment must allow for present and future needs. Calculations must be performed to ensure that floor loading capabilities are not exceeded.

The area must be clean, dry, and well ventilated. Provide adequate space and illumination for inspection, maintenance, testing, and cell/battery replacement. Space must also be provided to allow for operation of lifting equipment and taking system electrical measurements.

Seismic Considerations

When the installation is to be in a location subject to high probability of seismic disturbances, the racks, cabinets, anchors, and installation should be able to withstand the calculated seismic forces.

Always consult the local authority having jurisdiction (AHJ) for proper code compliance for installation of a battery system in a seismic zone or area.

Hydrogen Control [Ventilation]

During the operation, there is a slow build-up of hydrogen gas inside the VRLA batteries. When the internal pressure exceeds the valve release pressure, the hydrogen gas will be vented into the atmosphere. The following battery operating conditions have the following hydrogen generation effects:

- Minimal gas emission: open circuit, discharge, and initial recharge
- Occasional gas emission: float charge.
- Potential for maximum gas emission equalize charge and near end of recharge.
- Maximum gas emission: overcharge.

Adequate ventilation must be provided to prevent the possible accumulation of hydrogen. The amount of ventilation air flow must be ensured by natural ventilation, otherwise by forced (artificial) ventilation. Battery area or cabinet requires an air inlet and an air outlet with a minimum free area of opening.

NOTE - For safety reason, CSB highly recommends limiting hydrogen accumulation to less than 1% of the total volume of the battery area/cabinet.

NOTE - Always consult the local authority having jurisdiction (AHJ) for proper code compliance for installation of a battery system.

5. Battery Installation (Cont.)

Installation and Connections

After the initial design criteria is satisfied, the system is now ready to be physically installed in the desired location. CSB recommends following the steps listed below.

Pre-Inspection

Check the appearance of the batteries. Any battery with signs of physical defects or other damages cannot be installed in the system. Check the terminal appearance of the batteries. Any batteries with short circuit, impact or corrosion cannot be installed in the system.

Measure open circuit voltage and internal resistance of each battery before installation. Separate any block that falls out of ± 2 standard deviations. The blocks which sorted out need further observation (recharge and capacity test might be involved. [Contact CSB for technical support.]

Series or Parallel Connections

Below are diagrams meant to illustrate how to make a series or parallel connection with a VRLA-AGM battery type from CSB. Series connection increases battery DC voltage (Vdc) whereas parallel connection increases battery capacity.

If the voltage of the system where the batteries are installed exceeds 60V, a means of disconnecting shall be provided for all ungrounded conductors, as specified by Article 480 of NFPA 70 or Section 64 of CSA C22.1.

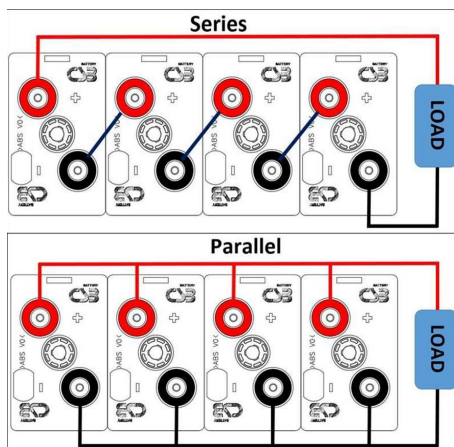

Series / Parallel Connection Diagram

Making Terminal Connections

Tighten connector bolts according to CSB recommended torque values. For nut and bolt assemblies, use a second wrench for counter torque. Use insulated wrenches.

Screw/ Bolt diameter	Torque value					
	Peak		Max		Min	
	Nm	kgf/m	Nm	kgf/m	Nm	kgf/m
M5	3.60	36.5	3.00	30.4	2.40	24.3
M6	6.10	62.0	5.10	51.7	4.10	41.4
M8	14.8	151.0	12.3	126.0	9.80	101.0
M10	29.3	299.0	24.4	249.0	19.5	199.0

- When connecting the battery to a charger or a load, keep the circuit switch OFF and connect the battery's positive (+) terminal to the positive (+) pole of the charger or the load and the battery's negative (-) terminal to the negative (-) pole of the charger or the load.
- Measure the voltage of the battery string to ensure that individual cells are connected correctly. [The total voltage should be approximately equal to the number of blocks multiplied by the individual block voltage.] If the measurement is less than expected, re-check the connections for proper polarity.
- Apply numbers to individual battery in sequences beginning with number one. CSB suggests starting from the first battery from negative polarity. For parallel strings, the blocks in each string must be numbered in the same polarity sequence starting with number one.

Freshening/Initial Charge

To compensate the self-discharge during the storage period, it is necessary to apply a freshening charge. Refer to Storage section for initial charge.

Periodically check the battery voltage, charge current, and temperature during the charge cycle. Observe the battery during the charge for unusual conditions. If the battery temperature rises more than 10°C during the charge, stop the charge and investigate. Contact CSB for technical support.

6. Charging

Standby Float Charge

To recharge and correctly maintain the charge of the batteries, CSB recommends constant voltage charge at $2.275 \pm 0.025V/cell$ (at $25^{\circ}C$). Initial charging current must be $0.3CA$ (where C stands for the nominal capacity value of batteries and A stands for "Amperes") or less. The ripple current must be limited $< 0.05CA$. The ripple voltage must be limited $< 0.5\% \times$ normal floating charging voltage (Vfloat). CSB recommends charging the battery at an ambient temperature between $5^{\circ}C$ and $35^{\circ}C$ to prevent any adverse effects on service life. It should be noted that for batteries connected in series, dispersion of floating voltage for each battery, caused by gas recombination, may be observed. This dispersion may be of $+6\% / -3\%$ at the start of the battery's life and $\pm 2\%$ after 6 months in the service.

Cyclic Applications

Maintain a modified constant voltage or a constant voltage at a voltage of $2.45 \pm 0.05V/cell$ (at $25^{\circ}C$); Initial charging current must be $0.3CA$ or less. To avoid overcharging, when charging is finished, CSB recommends charging to be stopped when the charging current has reduced to less than $0.05CA$ and must not continue for more than 24 hours before switch to floating charge mode ($2.275 \pm 0.025V/cell$, $25^{\circ}C$). CSB recommends charging the battery at an ambient temperature between $5^{\circ}C$ and $35^{\circ}C$ to prevent any adverse effects on its effective life.

Charging Time

CSB recommends for a charge limited to $0.1-0.3CA$, the floating recharge time for completely discharged batteries (100% depth of discharge) is approximately 72 hours (at minimum). In rapid charge with $2.50V/cell$ & $0.3CA$ as initial charging current, the recharge time for completely discharged batteries cannot be less than 8 hours. CSB suggests noticing below points:

CSB suggests noticing below points:

- The stage of charge must reach 110 - 120% to fully recharge the batteries to achieve 100% capacity available.
- The charge volume will be greater, for a given time, at high temperatures and lesser at lower temperatures.

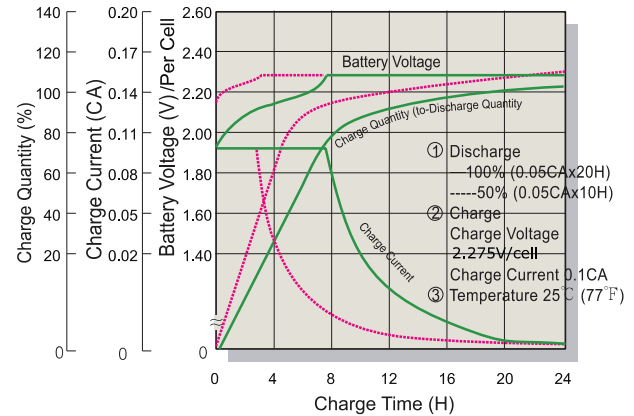

Figure 2 Charging Characteristics

Temperature Compensation

To optimize the service life of batteries, it is important to avoid all overcharge at high temperatures (risk of thermal runaway) or undercharge at low temperatures. Therefore, the temperature coefficient factor needs to apply.

Applications	Temperature coefficient
Cyclic	-5mV/ $^{\circ}C/cell$
Standby	-3.3mV/ $^{\circ}C/cell$

Temperature compensation is not necessary when the battery is charged at an ambient temperature between $5^{\circ}C$ to $35^{\circ}C$, with average temperature below $25^{\circ}C$. At temperatures below $5^{\circ}C$ or above $35^{\circ}C$, temperature compensation for charging voltage is necessary.

NOTE: The battery life will be shortened as the service temperature rises. Using the battery for a long period at the temperature over $40^{\circ}C$ may cause thermal runaway.

Equalization Charge

When batteries are used in serial, a single current is imposed on all the cells. However, if the voltages begin to differ, the result is a charge imbalance. To restore balance or at least prevent it from growing, equalization charging is required. Equalization charging characteristics are a constant voltage of $2.45V/cell$ for 5 to 8 hours. Excessive equalization charge can result in accelerated aging of VRLA batteries, reducing service life.

7. Discharging

The continuous discharge and maximum discharge current (for 5 seconds) should never exceed the values shown in the battery specification sheet. Never discharge the battery until the voltage and current are less than the values shown in battery specifications sheet. Repeated over-discharge will shorten the battery's life. After discharging, immediately recharge the battery. Never leave it discharged. The capacity to hold a charge may not be recovered if the battery is left discharged for a long period.

The chart below shows the evolution of battery voltage in relation to the regimes and discharge times (autonomy). The dotted line indicates the minimum recommended discharge voltage. To avoid deep discharge and deterioration of the batteries by plate sulfating, it is suggested not go below this final voltage.

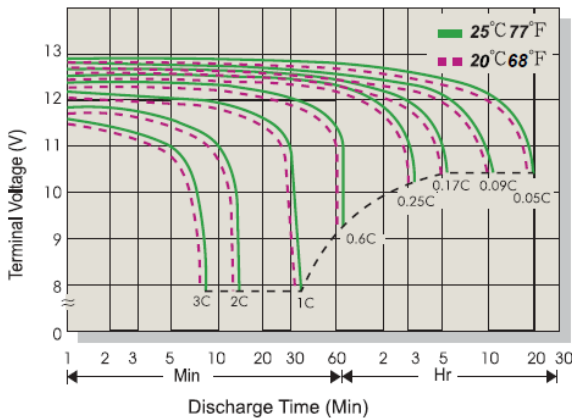

Figure 3 Terminal Voltage vs Time

Capacity vs. Temperature

The chart below shows the relation between temperature and discharge capacity. This figure shows the result of a charge at 25°C and discharge at various temperatures. Avoid operation of the battery below -15°C or beyond 50°C since damage may occur even though the battery may still operate.

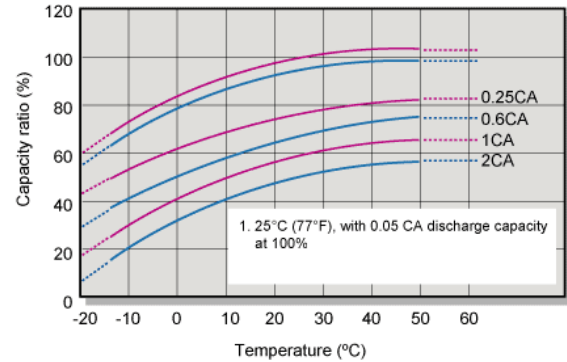

Figure 4 Temperature vs Discharge Capacity

Overdischarge

CSB VRLA batteries are capable of being recovered after accidental over-discharge and left standing in a discharged state for several days. However, it is necessary to avoid over-discharge situations as much as possible. The original capacity can be recovered after 2 or 3 consecutive over-discharges or leaving the battery in a discharged state. Beyond this limit, the battery may not recover to its original capacity. Always perform constant voltage charging with a 2.45V/cell with maximum current of 0.3CA. Recharge time > 24 hours. One recharge may not be sufficient to recover to the full capacity. In this case, repeat charge and discharge 2 or 3 more times.

8. Maintenance

For optimum reliability, it is recommended that the battery system be monitored regularly. If the battery system incorporates an automatic monitoring system to gather the electrical and environmental data, the quarterly checks are limited to the evaluation of the recorded data and a visual inspection of the battery. In general, the types of inspections to be made during periodic maintenance include:

- Visual battery inspection
- Battery system capacity test
- Battery system voltage inspection
- Ambient temperature
- Individual battery float voltage inspection
- High-rate load test
- Electrical resistance and tightness of inter-unit connections.



VRLA Battery User Manual

8. Maintenance (Cont.)

A test of the individual unit resistance, impedance, or conductance, while optional, is also recommended on a periodic basis. This data and its trends can be a valuable aid in troubleshooting the system and predicting the need for a system capacity test.

Prior to starting the periodic maintenance activity assure that all the required maintenance tools and equipment is available and functional. Notify anyone who will be affected by the intended maintenance or troubleshooting activity. All units in the battery should be numbered to facilitate the recording and analysis of data unique to each unit.

Tools and Equipment

At a minimum, the following tools and equipment are required to maintain and troubleshoot CSB's VRLA battery.

- Digital voltmeter
- Current clamp
- Impedance tester
- System load bank
- Recorder
- Insulated socket wrenches
- Insulated box end wrenches
- Torque wrench
- Screwdriver
- Rubber gloves
- Face shield or goggles
- Portable eyewash
- Fire extinguisher

Inspections

CSB recommends the following maintenance inspections with the following frequency below.

Frequency	Actions
Quarterly (Every 3 Months)	<p>Check that batteries are clean, free of debris. Ensure all facility safety equipment is available and functional. Visually inspect the battery for cleanliness, terminal damage, or evidence of heating container or cover damage.</p> <p>Measure DC voltage from each polarity of the battery to ground and detect any ground faults.</p> <p>Measure and record the DC float charging voltage, and current.</p> <p>Measure temperature of battery cabinet + inspections.</p>
Semi-Annual (Every 6 Months)	<p>Repeat quarterly inspections + randomly measure and record resistance/conductance of the individual units to trend the condition of the individual units over time and to detect dramatic differences between individual units and the average.</p>
Annual (Every 12 Months)	<p>Repeat the semiannual inspection + re-torque all the inter-unit connecting hardware.</p>
Bi-Annual (Every 24 Months)	<p>Capacity tests every two years at the service load or at the battery rating related to the service requirements.</p>



VRLA Battery User Manual

9. Troubleshooting

The following inspections, symptoms, and solutions are provided for reference. The actual judgments should be performed by CSB technical support. For assurance of system reliability, it is necessary to perform the recommended periodic maintenance. The recommended inspections should be performed at least on a quarterly basis. The recommended periodic inspections can be performed either manually or via automated monitoring systems. The recommended periodic inspections are designed to determine the gradual degradation of the system's capacity and to detect any abnormal system or individual battery condition which could impact system reliability.

Battery Visual Inspections

Symptom	Possible Causes	Possible Results	Corrective Actions
Cover /container cracked	Handling or impact damage	Cell dry out or ground fault. Potential internal gas ignition	Replace damaged unit
Cover /container explosion	Ignition of cell's internal gases due to external source, fusing of internal conductive path, or internal spark due to shorting. This potential exists for batteries left in service beyond their useful service life.	Personal injury and equipment damage at time of explosion. Failure to support load.	Replace damaged unit and evaluate any additional batteries
Signs of overheating on battery container	Crack in container causes leaking of electrolyte to grounded rack, etc. Ground fault	Could result in personnel hazard due to conductive path to rack, etc.	Clear the grounded fault and replace defective unit. Evaluate balance of string
		Could result in smoke or a battery fire	
		Could result in a thermal runaway	
Permanently deformed (swollen) container	Thermal runaway possibly caused by a high temperature environment, overcharging, excessively high recharge current, shorted cells, ground fault or a combination of these causes	Could result in the emission of hydrogen sulfide which is detectable as a rotten egg odor, battery fire and the inability to support the load	Replace the battery system and correct the items leading to the thermal runaway condition
Rotten egg odor	Possibly caused by a high temperature environment, overcharging or an excessively high recharge current, shorted cells of a combination of these causes	Odor is a product of extended thermal runaway	Replace the battery system and correct the items leading to the thermal runaway condition



VRLA Battery User Manual

Symptom	Possible Causes	Possible Results	Corrective Actions
Melted grease at terminal	Connections were hot due to excessive resistance caused by a loose connection, dirty contact surfaces or corrosion within the connection	Excessive voltage drop, perhaps leading to short operating time or damaged terminals. In extreme case, could lead to melted terminal and ignition of the battery cover	Clean and reassemble the connection if undamaged. Replace any battery with damaged terminals
Corrosion at terminals	These is possibly either residual electrolyte from manufacturing or electrolyte leaking from the battery terminal seal that is attacking the inner-unit connector	Increased connection resistance in the connection, lead to increased heating and voltage drop at high-rate discharge	Disassemble connection, clean, coat connecting surfaces and terminal area and seal with anti-oxidation grease and appropriately reassemble the connection. If leakage about the terminal area is obvious, the battery should be replaced.

Battery Capacity Test Results

Symptom	Possible Causes	Possible Results	Corrective Actions
Reduced run time at 25°C with smooth voltage decline	Normal wear out	Eventual failure to support the load followed by potential for shorted cells.	Replace battery system when at 80% of rated capacity or before
Reduced run time at 25°C with steep voltage decline or voltage plateaus	Individual low-capacity cells	Reversed cells during discharge. Reversed cells will become very hot and will not recharge	Replace the isolated low-capacity batteries
Excessive initial voltage drop even to the point of dropping load in the first several Seconds	Battery is cold		Warm up the battery
	Cabling is too small	Excessive voltage drop	Add parallel cables
	High resistance connections	Excessive voltage drop	Clean and reassemble connections
	Battery is undersized		Add required parallel strings
	Shorted cells	Cells will become hot, could develop thermal runaway, internal arcing could result in explosion	Replace isolated units with shorts and evaluate entire string



VRLA Battery User Manual

Battery Float Current

Symptom	Possible Causes	Possible Results	Corrective Actions
Float current to the string is zero	A battery or connection in the series string is open. This can be verified via the float voltage or impedance check of the individual batteries.	Failure to support the load. If an internal arc should occur during discharge, it could ignite the internal gases of the cell.	Replace the battery with the open cell or repair the open/loose external connection.
		If there is an open/loose connection in the external conductive path, it could damage the termination under load.	
Float current exceeds 0.03CA at 25°C with float charge.	Batteries are not yet fully recharged	Not at 100% of capability	Determine the specific cause and take the necessary corrective action
	Batteries are above 25°C	Leads to thermal runaway	
	Potentially shorted cells in battery	Leads to thermal runaway	
	Depending on the degree, the battery may be entering or in thermal runaway	Thermal runaway results in eventual meltdown of the battery and the potential of hydrogen sulfide emissions and fire	
AC ripple current exceeds 5 amperes per 100 Ah rated battery capacity	Poor filtering of the charger	Excessive AC ripple current will result in battery heating	Improve the charger output filtering



VRLA Battery User Manual

Battery DC Voltage

Symptoms	Possible Causes	Possible Results	Corrective Actions
System float voltage greater than 2.3 V/cell at an average temperature of 25°C	Charger output voltage set incorrectly	Overcharging will cause excessive gassing and drying of the electrolyte, potential of thermal runaway	Reset the charge output voltage to the recommended value
System float voltage less than an average of 2.25 V/cell	Charger output voltage set incorrectly	Undercharging will result in gradual loss of operation time and capacity with successive discharge cycles. If allowed to persist, an irreversible level of lead sulfate will develop on the plates with the result of a permanent loss of capacity.	Reset the charger output voltage to the recommended value. Equalize the battery system for 48 to 72 hours and perform a capacity test. If loss is permanent, replace the total battery system
System equalize voltage is greater than an average of 2.45 V/cell	Charger equalization voltage is set incorrectly	Overcharging will cause excessive gassing and drying of the electrolyte and will contribute to potential thermal runaway	Reset the charger output voltage to the recommended value
System equalize voltage is less than an average of 2.45 V/cell	Charger equalization voltage is set incorrectly	Equalization and boost charging will be less effective and will require extended time	If possible, reset the charger output voltage to the recommended value or accept a longer equalization time
Individual battery float voltage less than an average of 2.2 V/cell (13.3 VDC for 6 cell battery, 11.1 VDC for 5 cell battery, 6.6 VDC for 3 cell battery)	Potentially the individual battery has a shorted cell. This could be verified with an impedance or conductance check	Reduced operating time under a load, increased float current, heating during discharge, contributes to potential thermal runaway	Replace the individual battery
Individual battery float voltage greater than an average of 2.42 V/cell (14.5 VDC for 6 cell battery, 12.1 for 5 cell battery, 7.3 for 3 cell battery)	Potentially there may be an open cell in the individual battery. This can be confirmed by checking for zero float current or checking for a very high impedance of the battery.	Failure to support the load. Could result in an internal arc which could ignite the gasses within the cell	Replace the individual battery
DC voltage measured between either of the battery system output terminals and ground (rack) or a ground fault indicated by automatic monitoring equipment	Damaged battery container allowing electrolyte to leak out to the grounded surface (rack)	Personnel shock hazard which could result in serious injury or electrocution. Potential burning of the container at damaged area or battery fire	Determine the source of the ground fault and replace the battery



VRLA Battery User Manual

Battery Temperature

Symptom	Possible Causes	Possible Results	Corrective Actions
Elevated room temperature	Lack of adequate air conditioning/ventilation	Reduced battery life	Cool the room or accept reduced battery life
Elevated battery temperature	Elevated room temperature	Reduced life and potential thermal runaway	Improve room air conditioning
	Inadequate cabinet ventilation	Reduced life and potential thermal runaway	Improved cabinet ventilation and temperature
	Discharge-Charge cycle	Can be normal if not exceeding 10°C increase	Limit recharge current
	AC ripple current greater than 5 amperes rms/100 Ah battery capacity	Reduced life and potential thermal runaway	Determine the cause of the excessive AC ripple current and correct
High current recharge	High charging voltage	The combination can lead to thermal runaway	Limit recharge current
			Reduce to within specifications
	Shorted cells		Reduce shorted cells and evaluate total string

Battery High-Rate 10 Second Load Test

Symptom	Possible Causes	Possible Results	Corrective Actions
Terminal voltage is marginally below the minimum voltage specified for 10 Second point	Battery could not be fully charged or is an older battery that has been in service and has a somewhat lower capacity	Could have a reduced operating time	Fully recharge the battery
Terminal voltage is significantly below the minimum voltage specified for 10 Second point	Battery is discharged or there is deterioration of the conductive path, plate grid, active material, or electrolyte volume	Reduced operating time	Charge and reset battery or replace as required
	Shorted	Conductive to thermal runaway	
	Open cells	Will not support load	



VRLA Battery User Manual

Battery AC Ripple Voltage

Symptom	Possible Causes	Possible Results	Corrective Actions
AC ripple (p-p) voltage on the system is greater than 4% of the value of the DC float voltage	Poor filtering of the charger output	Excessive AC ripple could cause the battery to cycle at the ripple frequency and result in heating and deterioration of the active plate material	Improve the charger output filtering
Individual battery in string exhibits AC ripple voltage of twice that of the other typical batteries in the string	Battery with the high AC ripple voltage has proportionately higher impedance and should be further evaluated for performance. Subject battery could have a deteriorating conductive path or a dry, shorted, or open cell	Reduce operating time Potential conditions could be conducive to thermal runaway	Verify the battery condition and replace as required

Battery Connection Hardware

Symptom	Possible Causes	Possible Results	Corrective Actions
Connection resistance increase of 20% or more from original value	Repetitive cycles resulting in heating and cooling of connection can result in relaxation of torque and an increase in connection resistance	Loose connections can result in heat damaged or melted terminals during high-rate discharge	Re-torque the connection as required
	Contamination within the connection can result in corrosion and high terminal resistance	Excessive voltage drop during high-rate discharge resulting in reduced operating time	
Connection hardware tightness is less than the specified re-torque value	Repetitive cycles resulting in heating and cooling of connection can result in relaxation of torque and an increase in connection resistance	Loose connections can result in heat damaged or melted terminals during high-rate discharge	Re-torque the connection as required
When new impedance/resistance increases by 50% from original value or conductance declines to 50%	Battery is discharged or there is deterioration of the conductive path, plate grid, active material, or electrolyte volume	Reduced operating time	Charge and reset battery or replace as required
	Shorted cells	Conductive to thermal runaway	
	Open cells	Will not support load	



VRLA Battery User Manual

10. Warranty

Terms and Conditions

CSB Energy Technology Co., LTD ("CSB") conditionally warrants to PURCHASER of the Products, that the Product, as delivered: (i) is free from defects in material, workmanship and title; (ii) conforms to CSB's published or designated specifications for the Product's physical characteristics, operating parameters and performance ("the Specifications"), and (iii) should PURCHASER discover and report any defects or nonconformities in the Product to CSB within the warranted period, CSB, upon satisfactory investigation of PURCHASER's claim, shall correct such defect or nonconformity either, at its sole option, (i) by repairing any defective or damaged part or parts of the Products; (ii) making available FOB PURCHASER's facility, a replacement Product or any necessary repaired or replacement parts; or (iii) providing a credit to PURCHASER in the amount of the purchase price of the Product, each exclusive of any labor, installation, transportation, service or test related costs or charges ("the Warranty"). Upon return by PURCHASER under the Warranty, all defective or nonconforming Products that are replaced by CSB shall become the property of CSB. The Warranty is subject to the following conditions:

1. The Product must have been installed, charged, discharged, stored, used, and maintained in accordance with CSB's current printed instructions and the Specifications.
2. The Warranty Period for any Product which has been installed in an environment where the temperature exceeds 25°C (77°F) shall be proportionately reduced by fifty percent (50%) for every 10°C increase in temperature above 25°C unless otherwise stated. Operation or storage of the Product for any length of time in an environment having a temperature above 50°C will void the Warranty.
3. Unless otherwise stated in writing from CSB for specific warranty conditions in an intended application, for products used in an application not intended or designed to perform as outlined in table below shall be considered void of Warranty and not eligible for warranty replacement or credit.
4. A Product will be considered defective or nonconforming if it has not delivered at least eighty percent (80%) of its rated capacity during the Warranty Period. This will be determined by recharging the battery for 48 hours, then discharging and measuring the amount of Ah used versus the Ah capacity of the battery.
5. Product must be of proper capacity and size for the intended application.
6. The Product has not been subjected to misuse, abuse, or physical damage.
7. PURCHASER has promptly notified CSB of any defects or nonconformities and cooperated with CSB by making the Product available for assessment and/or repair by CSB.
8. It shall not be deemed necessary for defective or nonconforming Products to be returned to the CSB for credit if the quantity involved is < 4 units. However, the claim must be accompanied by a field service report containing the relevant readings and details of the failure. Quantities of > 4 units must be returned for CSB to determine the failure mode.
9. Upon request of CSB, PURCHASER shall have promptly returned to CSB, FOB shipping point-freight prepaid, any Product believed to be defective or nonconforming. PURCHASER must request and receive from CSB a Return Material Authorization (RMA) for any Product believed to be defective or nonconforming prior to returning such Product to CSB.
10. The Warranty shall be enforceable by the PURCHASER of the Products and is non-transferable.



VRLA Battery User Manual

11. The Warranty shall be rendered void if the Product is serviced by any party other than a representative from one of PURCHASER's authorized Service Centers or a party which PURCHASER's Service Department has pre-approved in writing or if Product has not been serviced per PURCHASER's instructions.
12. The warranty will be void if the Product becomes unserviceable due to fire, wreckage, neglect, freezing, abuse, any act of God, the use of battery additions.
13. CSB makes no warranty and shall have no obligation for any damage to the Product caused by or resulting from abuse, misuse, neglect or any unauthorized repairs, maintenance, or alterations of the Product.

The preceding paragraphs set forth the exclusive remedies of PURCHASER for all claims based on a defect in or nonconformity of the Product, whether the defect or nonconformity arises before or during the warranty period, and whether a claim, however instituted, is based on contract, indemnity, warranty, tort (including negligence and strict liability), or otherwise.

CSB ENERGY TECHNOLOGY CO., LTD LIABILITY FOR ANY BREACH OF THE WARRANTY IS LIMITED AS SET FORTH IN THE WARRANTY. THE WARRANTY IS EXCLUSIVE AND IN LIEU OF ALL OTHER WARRANTIES, EXPRESS, IMPLIED OR STATUTORY INCLUDING, WITHOUT LIMITATION, IMPLIED WARRANTIES OF MERCHANTABILITY AND FITNESS FOR A PARTICULAR PURPOSE. UNDER NO CIRCUMSTANCES SHALL CSB ENERGY TECHNOLOGY BE SUBJECT TO ANY CONSEQUENTIAL, INCIDENTAL, INDIRECT, SPECIAL OR CONTINGENT DAMAGES WHATSOEVER, INCLUDING BUT NOT LIMITED TO DAMAGES FOR LOST PROFITS OR GOODWILL.



VRLA Battery User Manual

This Page Left Intentionally Blank



VRLA Battery User Manual

CSB Energy Technology - Contact Us

For inquiries or support, please reach out to any of our global offices listed below:

CSB Energy Technology Co., Ltd.

Global HQ

11F, No. 150, Sec. 4, Chengde Rd., Shilin Dist.,

Taipei City 111052, Taiwan (R.O.C.)

Tel: +886-2-2880-5600

Fax: +886-2-2888-3300

Email: service@csb-battery.com.tw

CSB Energy Technology (Americas) Co., Ltd.

America HQ

4008 Clay Avenue, Suite 210, Haltom City, TX 76117, U.S.A.

Tel: +1-817-244-7777 / 1-(800)-3-CSB-USA (272872)

Fax: +1-817-244-4445

Email: service@csb-battery.com

CSB Energy Technology (EMEA) B.V.

Europe HQ

Keurmeesterstraat 28-30, 2984 BA, Ridderkerk, The Netherlands

Tel: +31(0) 180 418140

Email: service@csb-battery.eu

CSB Energy Technology (Shanghai) Co., Ltd.

Shanghai Branch

Room 2304, No. 76, Pujian Road, Shanghai, China

PC: 200127

Tel: +86-21-50461622 / +86-21-50460833 / +86-21-50460094

Fax: +86-21-50461046

Email: service@csb-battery.com.cn

CSB Energy Technology (ShaoGuan) Co., Ltd.

Shenzhen Branch

Room 209, Floor 2, Building A, Xinsheng Plaza, No. 86, Puxia Road,

Liyue Community, Henggang Street, Longgang District, Shenzhen, China PC: 518102

Tel: +86-755-88316075 / +86-755-88316488 / +86-755-88316775

Fax: +86-755-88316548

Email: service@csb-battery.com.cn

For more information, please visit our website: www.csb-battery.com